

**MODEL WSP-i350**

**(3inch Industrial Printer)**

**Rev. 2.0**

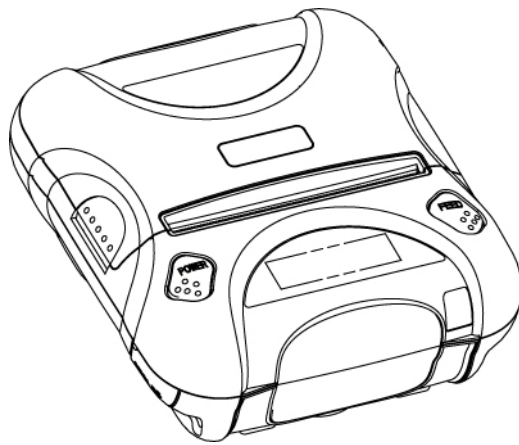

**WOOSIM SYSTEMS Inc.**

**#501, Daerung Technotown 3th,  
448, Gasan-Dong, GeumChun-Ku,  
Seoul, Korea**

**Tel : +82-2-2107-3700**

**Fax : +82-2-2107-3707**

**URL: <http://www.woosim.com>**

All specifications are subjected to change without notice

## ! Copyright

**WSP-i350** 3inch Industrial printer operator's manual.

Copyright 2009 by Woosim Systems Inc.

All rights reserved.

The information contained in this manual is the property of Woosim Systems Inc.

and may not be reproduced in whole or in part without the prior written permission of Woosim Systems Inc.

## ! Trademark



a registered trademark of Woosim Systems Inc.

All other trademark are the properties of their respective companies.

## ! Caution

Some semiconductor devices are easily damaged by static electricity. You should turn the printer "OFF", before you connect or removed the cable on the rear side, in order to guard the printer against the static electricity.

If the printer is damaged by the static electricity, you should turn the printer "OFF"

## ! Notice

The contents of this manual are subject to change without notice.

## | Introduction

The **WSP-i350** is the ideal solution for Mobile banking system , Retail, point of sales, Credit card Transaction, other traveling and mobile computing etc.

The general features of WSP-i350 printer are as follows:

- U Pocket size (120 × 130.5 × 58.3mm)
- U Light weight(560g) for true mobility [standard]
- U Very silent printing thru direct thermal printing method
- U High speed (80mm/sec, MAX)
- U High resolution(203dpi : 8dots/mm).
- U UART(RS-232C or TTL), Bluetooth Ver2.1 + EDR, IrDA Ver1.0(SIR) [option]  
Wireless LAN (IEEE802.11b/g)[option] interface
- U Support Magnetic Stripe Reader[option]
- U Support Graphic LCD(128 × 32dots) with Blue LED Backlight
- U Intuitive LED's indicate Power(on/off),Error and Battery status
- U Support text and graphic printing
- U Easier paper roll loading by CLAMSHELL design
- U One touch paper cover
- U Printer door open & Paper-out sensor
- U Easier maintenance with self-diagnostic.
- U In field programming – Update Firmware, Download Fonts and Logos
- U Compact and easy to carry around.
- U Water-resistant construction.( IP54 – Certified )
- U Microsoft Windows 98 /ME /2000 / XP / VISTA / 7 compatible.
- U Flow control : Software (XON/XOFF)  
Hardware flow control not supported in printer.
- U Free fall: 1 meter onto concrete (option 1.5 meter)
- U Agency Approvals



## ! Operating Precautions

Please follow the precautions below to enjoy and maintain the full performance of the printer.

### U Using the Printer

- Be careful not to drop or bump the printer on a hard surface.
- Do not install the printer in direct sunlight or such areas.  
Suitable environment for the use of the printer is as follows:  
Operating temperature :-10°C to 50°C  
Relative humidity : 10% to 90% (No condensation)
- Do not install the printer near devices that generate strong electromagnetic fields such as a copy machine.
- Do not open the platen cover during printing .
- Do not remove or reinstall the communication cable during printing or transmission.
- Do not touch the connectors of the communication during printing.
- Switch the POWER OFF when not in use.
- Do not use alcohol or other solvent.
- The AC adapter, the battery charger and the battery pack may become warm when in use. This is normal and is not a malfunction.
- When the battery pack is used at low temperature, the length of time the printer can be used may be shortened.

### U Thermal Paper Handling

- Store the thermal paper in a cool, dry and dark place.
- Do not rub the paper with hard object.
- Do not leave the paper with hard object.
- Do not allow plastic film, erasers, or adhesive tape to touch the paper for long periods.
- Do not stack the thermal paper with diazo copies immediately after copying or wet-type copies.
- Do not use chemical glue.
- Always use the clean thermal paper.

**| Note**

This equipment has been tested and found to comply with the limits for a Class B digital device, pursuant to Part 15 the FCC Rules.

These limits are designed to provide reasonable protection against harmful interference in a residential installation.

These equipment generates, uses and can radiate radio frequency energy and, if not installed and used in accordance with the instructions, may cause harmful interference to radio communications.

However, there is no guarantee that interference will not occur in a particular installation.

If this equipment does cause harmful interference to radio or television reception , which can be determined by turning the equipment off and on, the user is encouraged to try to correct the interference by one or more of the following measures:

- Reorient or relocate the receiving antenna.
- Increase the separation between the equipment and receiver.
- Connect the equipment into an outlet on a circuit different from that to which the receiver is connected.
- Consult the dealer or an experienced radio/TV technician for help.

# CONTENTS

<b>1. Outline</b> .....	<b>7</b>
1.1. Model classifications .....	7
1.2. Product Part Number System.....	7
1.3. Specifications.....	8
<b>2. Setting up the printer</b> .....	<b>9</b>
2.1. Printer & Accessories.....	10
2.2. Printer Features .....	11
2.3. Replacing paper roll.....	13
2.4. Power supply .....	14
2.4.1. Specified power supply.....	14
2.4.2. Installing the battery and the belt strap .....	14
2.4.3. Recharging the battery pack.....	15
2.5. Set operation mode .....	16
<b>3. Interface</b> .....	<b>24</b>
3.1. UART(RS-232C or TTL).....	24
3.2. Infrared data communication .....	25
3.3. Bluetooth .....	26
3.4. Wireless LAN .....	26
<b>4. Using the printer</b> .....	<b>27</b>
4.1. Control panel .....	27
4.2. The self test .....	28
<b>5. Consumable Parts</b> .....	<b>29</b>
5.1. Recommended paper.....	29
5.2. Printing position.....	29

# 1. Outline.

## 1.1. Model classifications.

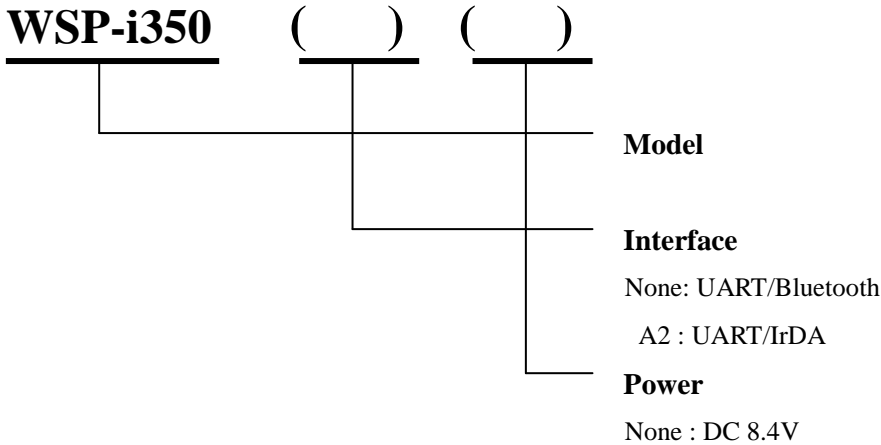

## 1.2. Product Part Number System.

**Model name / Interface Spec.**

<p>S40 SC30 W25 . . .</p>	<table border="1" style="width: 100%; border-collapse: collapse;"> <thead> <tr> <th colspan="2">Wired</th> <th colspan="2">Wireless</th> </tr> </thead> <tbody> <tr> <td>A</td> <td>RS-232C</td> <td>1</td> <td>Bluetooth</td> </tr> <tr> <td>B</td> <td>TTL</td> <td>2</td> <td>IrDA</td> </tr> <tr> <td>C</td> <td>USB</td> <td>0</td> <td>None</td> </tr> <tr> <td>D</td> <td>RS-485</td> <td></td> <td></td> </tr> <tr> <td>E</td> <td>Parallel</td> <td></td> <td></td> </tr> <tr> <td>Z</td> <td>None</td> <td></td> <td></td> </tr> </tbody> </table>	Wired		Wireless		A	RS-232C	1	Bluetooth	B	TTL	2	IrDA	C	USB	0	None	D	RS-485			E	Parallel			Z	None		
Wired		Wireless																											
A	RS-232C	1	Bluetooth																										
B	TTL	2	IrDA																										
C	USB	0	None																										
D	RS-485																												
E	Parallel																												
Z	None																												

Example) 1. Porti-S40    Serial/Bluetooth    Part No.    S40/A1  
 2. Porti-SC30    Bluetooth Only    Part No.    SC30/Z1

### 1.3. Specifications.

Item	Specifications
<b>Print method</b>	Direct thermal line printing
<b>Characters per line</b>	64cpl (MAX)
<b>Character size</b>	Eng. : 9×24dots, 12×24dots    Kor. : 16×24dots, [24×24dots]
<b>Optional Characters</b>	Simplified/Traditional Chinese, Arabic, Cyrillic, Russian, Turkish, Greek, Japanese, Persian, Latin9 and Others upon request.
<b>Resolution</b>	203dpi, 8dots/mm
<b>Print width</b>	3-inch (72mm, 576dots)
<b>Print speed</b>	80mm / sec (MAX)
<b>Dimension</b>	120×130.5×58.3 mm
<b>Weight</b>	560g (Including battery & roll paper) [standard] 566g (Including battery & roll paper) [MSR]
<b>Interface</b>	UART(RS-232C or TTL), Bluetooth Ver 2.1 + EDR IrDA Ver1.0(SIR) [option], Wireless LAN interface(IEEE802.11b/g) [option]
<b>Paper roll</b>	Thermal roll paper (80mm wide, 50φ)
<b>Barcodes</b>	1-dimension : Code128, Code39, I2/5, Code93 UPC, EAN, KAN, JAN, CODABAR 2-dimension : PDF417, QR Code, DATA Matrix
<b>Black mark</b>	Support black mark detection
<b>H/W Spec.</b>	MCU : 32bits RISC, FLASH : 4M bytes, RAM : 8M bytes
<b>Receive buffer size</b>	1M bytes
<b>MSR</b>	ISO 7810 / 7811 / 7812    1&2 or 2&3 Track Reading
<b>LCD</b>	128 × 32 Dots FSTN (Blue LED Backlight)
<b>Battery</b>	Rechargeable 7.4V DC, 1,800mAh (Li-ion)
<b>Battery duration</b>	1 hour continuous printing
<b>Battery charger</b>	Input (100~250V AC, 50~60Hz) Output(8.4VDC/0.8A), 4hours full charge time

( Continue... )

Item	Specifications	
Environment conditions	Temperature	-10°C ~ 50°C (operating) -10°C ~ 70°C (storage)
	Humidity	30% - 80% (operating) 10% - 90% (storage)
MCBF(Mean Cycle Between Failure)	Mechanical	37,000,000 lines
	Head	Approximately 50 Km

&lt; Table 1 &gt;

## 2. Setting up the printer.

### 2.1. Printer & Accessories

Your printer box should include these items. If any items are damaged or missing, please contact your dealer for assistance.



**WSP-i350**



**Battery pack**



**Thermal roll paper**



**Battery charger adaptor**

#### OPTIONAL



**Communication cable**



**Shoulder band**



**MSR**

## 2.2. Printer Features

### Part Name

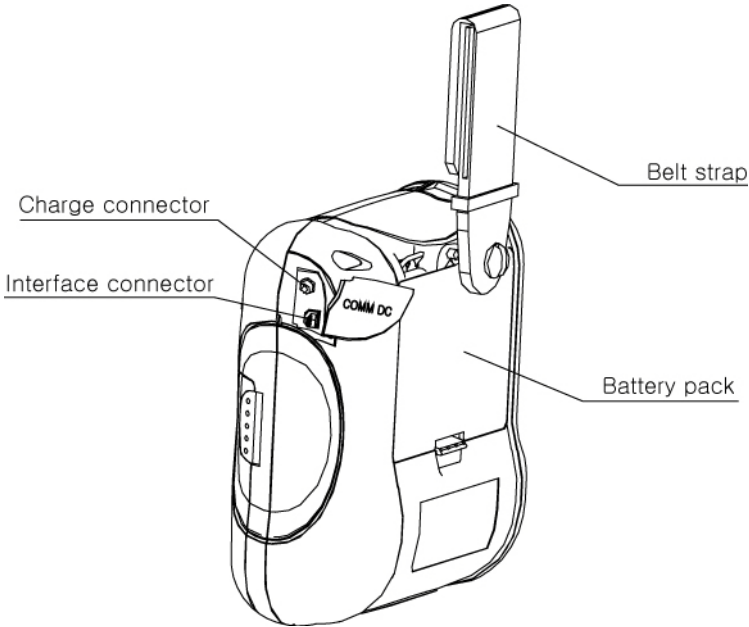
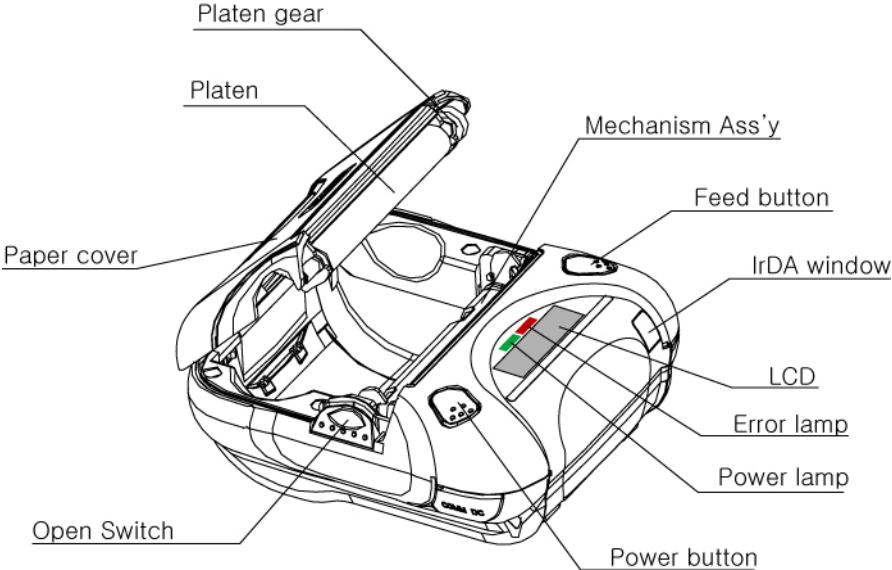

Dimensions

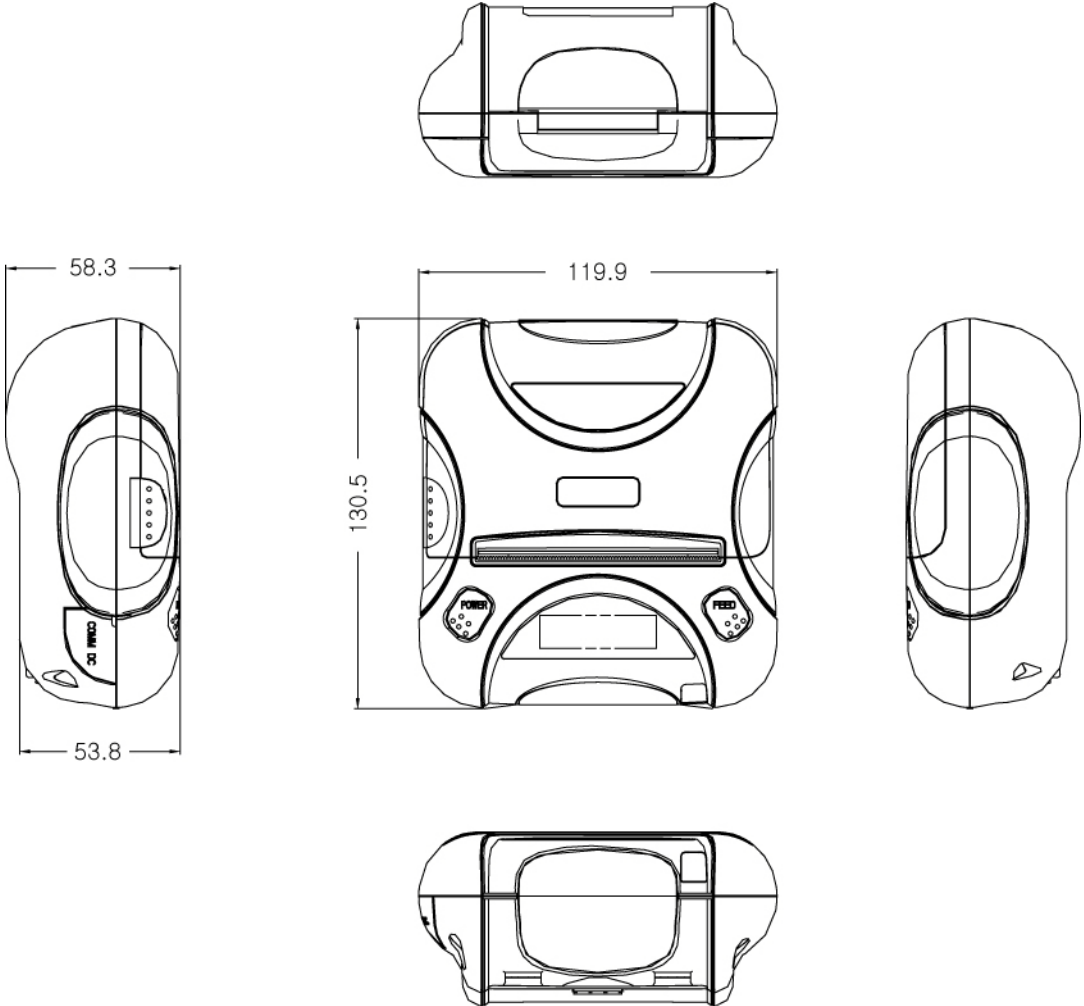

## 2.3. Replacing paper roll.

Note : Be sure to use paper rolls that meet the specifications.

Do not use paper rolls that have the paper glued to the core because the printer can not detect the paper end correctly.

1. Make sure that the printer is not receiving data; otherwise, data may be lost.
2. Open the paper cover by placing your fingers under the paper cover lock and pull a paper cover lock open.

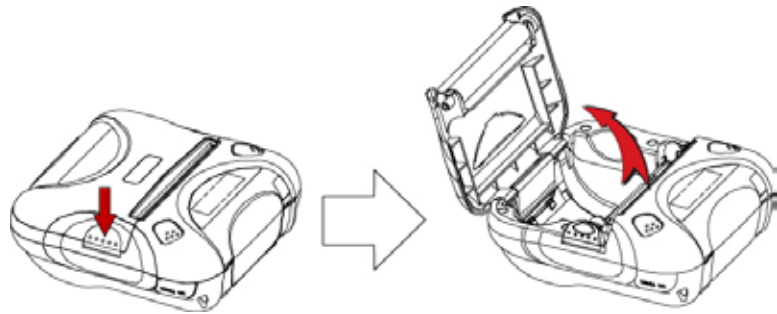

3. Insert a new paper roll as shown.

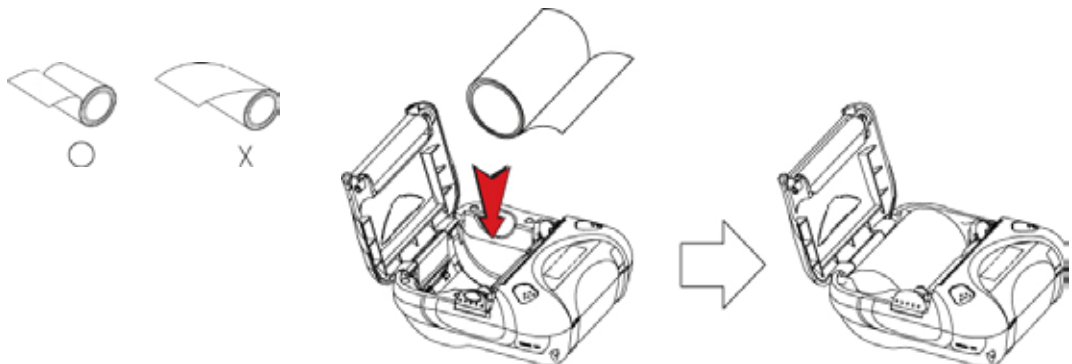

4. Tear the excess paper off using the edge of paper door as a tear bar.

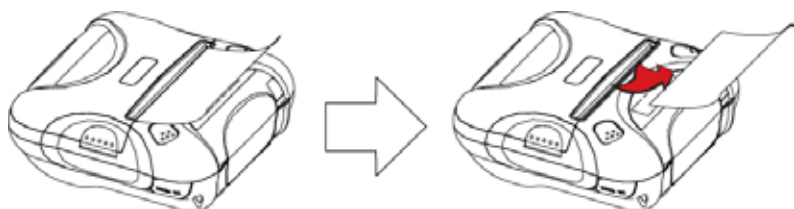

## 2.4. Power supply

### 2.4.1. Specified power supply.

The following specification is requested for Power supply.

Battery Charger : DC 8.4V/0.8A

Avoid using power supply which its power capacity of power current is extremely high.

### 2.4.2. Installing the battery and the belt strap

**NOTE :**

- Before installing or removing the battery pack, ensure the printer is **OFF**.
- If the printer is not used for long period of time, remove the battery pack from the printer.

#### \*\* BATTERY \*\*

To install battery pack, proceed as follows:

- Insert the Battery pack in the direction of the arrow.

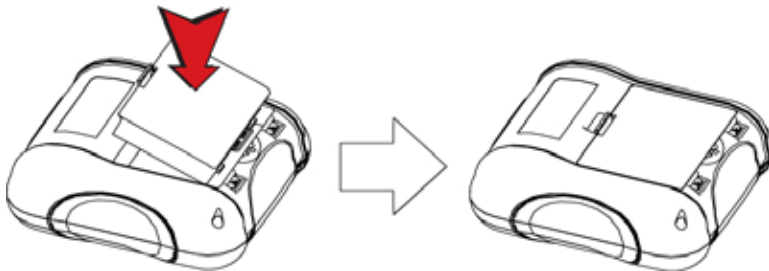

Reverse the order to remove the battery pack.

#### \*\* BELT STRAP \*\*

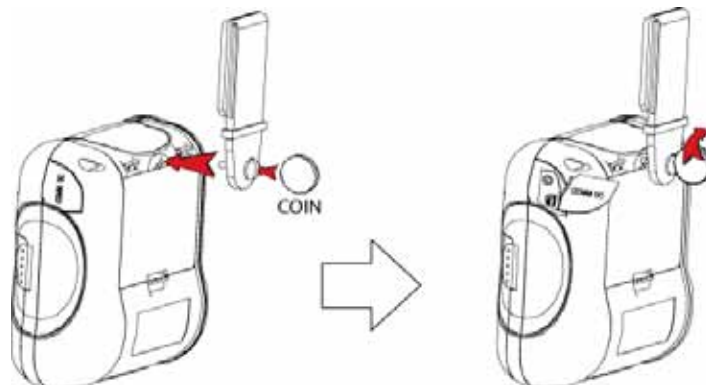

### 2.4.3. Recharging the battery pack

For recharging the battery pack, install the battery pack in the printer.  
Insert the Battery Charger to the charge connector of the printer.

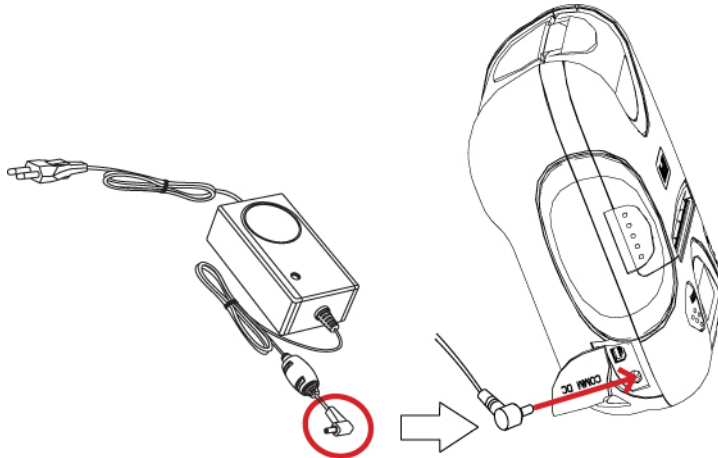

- NOTE :**
- While charging the printer, turn off the printer power.
  - Do not remove the battery during charging.
  - The battery is consumable parts and when purchasing, compared to the use hour is gradually decreases. (Warranty 6 month)
  - If the printer is not used for a long time, unplug the power cord from the printer and outlet.
  - The recharging time depends on the voltage level and ambient temperature of the battery. Normally, it takes about 4 to 5 hours to recharge a battery pack.
  - You must use only the supplied adapter.
  - Red Lamp : charging the battery.
  - Green Lamp: charging is finished.

## 2.5. Set operation mode.

Change the mode and option using the mode Code.

┆ **MODE button** : changing Printer MODE status. (**Error Lamp**)

┆ **FEED button** : changing OPTION status.

[Example] The defaults of the printer are :

UART / 9600 bps / 8 data bit / No parity / 1 stop bit / Density low / Quality low

/ Mark use / Sensor low / Power down 5 minute

If a user wants to modify the defaults with

Bluetooth / 57,600 bps / 7 data bit / Odd parity / 2 stop bit / Density high / Quality high

/ Mark no use / Sensor medium1 / Power down no use

┆ Press **MODE Button** during the **Error Lamp** flickers 5 times.

Ⓜ You will see present **COMMUNICATION** mode in the LCD.

Ⓜ Press the **MODE Button** twice.

And then, interface mode has set to **Bluetooth** mode.

┆ When you press **FEED button** once.

Ⓜ You will see present **BAUD RATE** mode in the LCD.

Ⓜ Press **MODE Button** 3 times.

And then, baudrate has set to **57,600 bps**.

┆ When you press **FEED button** once.

Ⓜ You will see present **DATA BIT** mode in the LCD.

Ⓜ Press **MODE Button** once.

And then Data Bit has set to **7 data bit**.

┆ When you press **FEED button** once.

Ⓜ You will see present **PARITY** mode in the LCD.

Ⓜ Press **MODE Button** once.

And then the Parity bit has set to **Odd parity bit**.

┆ When you press **FEED button** once.

Ⓜ You will see present **STOP BIT** mode in the LCD.

Ⓜ Press **MODE Button** once.

And then the density has set to **2 stop bit**.

- ⌋ When you press **FEED button** once.
  - Ⓜ You will see present **DENSITY** mode in the LCD.
  - Ⓜ Press **MODE Button** twice.  
And then the density has set to **Density high**.
- ⌋ When you press **FEED button** once.
  - Ⓜ You will see present **Quality** mode in the LCD.
  - Ⓜ Press **MODE Button** once.  
And then the quality has set to **Quality high**.
- ⌋ When you press **FEED button** once.
  - Ⓜ You will see present **MARK** mode in the LCD.
  - Ⓜ Press **MODE Button** once.  
And then the mark has set to **Mark no use**.
- ⌋ When you press **FEED button** once.
  - Ⓜ You will see present **SENSOR** mode in the LCD.
  - Ⓜ Press **MODE Button** once.  
And then the sensor has set to **Sensor medium1**.
- ⌋ When you press **FEED button** once.
  - Ⓜ You will see present **PWDN** mode in the LCD.
  - Ⓜ Press **MODE Button** once.  
And then the Power down has set to **Power down no use**.

If all the mode have set, press the **MODE Button** and the **FEED Button** at the same time after then release the buttons at the same time.

The printer will print out the mode status which has modified.

**(Bluetooth / 57600 bps / 7 data bit / Odd parity / 2 stop bit / Density high / Quality high  
Mark no use / Sensor medium1 / Power down no use)**

If the status is not correct, please try it again according to the procedure.

## \* IrDA Version

	POWER Lamp (Green)	ERROR Lamp (Red)	Option
<b>Communication Port</b>	1	1	UART(RS-232C)
		2	Protocol UART(RS-232C)
		3	Raw IrDA
		4	Protocol IrDA
		5	Standard IrDA
<b>Baud Rate</b>	2	1	9600 bps
		2	19200 bps
		3	38400 bps
		4	57600 bps
		5	115200 bps
<b>Data Bit</b>	3	1	7 Data bit
		2	8 Data bit
<b>Parity Bit</b>	4	1	No Parity
		2	Odd Parity
		3	Even Parity
<b>Stop Bit</b>	5	1	1 Stop bit
		2	2 Stop bit
<b>Density</b>	6	1	Density Low
		2	Density Medium
		3	Density High
<b>Quality</b>	7	1	Low
		2	High

(Continue...)

	<b>POWER Lamp (Green)</b>	<b>ERROR Lamp (Red)</b>	<b>Option</b>
<b>Mark</b>	8	1	No use
		2	Use
<b>Sensor</b>	9	1	Low
		2	Medium1
		3	Medium2
		4	High
<b>Power Down</b>	10	1	No use
		2	1 minute
		3	2 minute
		4	3 minute
		5	4 minute
		6	5 minute

< Table 2 >

## \* Bluetooth Version

	POWER Lamp (Green)	ERROR Lamp (Red)	Option
Communication Port	1	1	UART(RS-232C)
		2	Protocol UART(RS-232C)
		3	Bluetooth
		4	Protocol Bluetooth
Baud Rate	2	1	9600 bps
		2	19200 bps
		3	38400 bps
		4	57600 bps
		5	115200 bps
Data Bit	3	1	7 Data bit
		2	8 Data bit
Parity Bit	4	1	No Parity
		2	Odd Parity
		3	Even Parity
Stop Bit	5	1	1 Stop bit
		2	2 Stop bit
Density	6	1	Density Low
		2	Density Medium
		3	Density High
Quality	7	1	Low
		2	High

(Continue...)

	<b>POWER Lamp (Green)</b>	<b>ERROR Lamp (Red)</b>	<b>Option</b>
<b>Mark</b>	8	1	No use
		2	Use
<b>Sensor</b>	9	1	Low
		2	Medium1
		3	Medium2
		4	High
<b>Power Down</b>	10	1	No use
		2	1 minute
		3	2 minute
		4	3 minute
		5	4 minute
		6	5 minute

&lt; Table 3 &gt;

## \* WLAN Version

	POWER Lamp (Green)	ERROR Lamp (Red)	Option
Communication Port	1	1	UART(RS-232C)
		2	Protocol UART(RS-232C)
		3	WLAN
		4	Protocol WLAN
Baud Rate	2	1	9600 bps
		2	19200 bps
		3	38400 bps
		4	57600 bps
		5	115200 bps
Data Bit	3	1	7 Data bit
		2	8 Data bit
Parity Bit	4	1	No Parity
		2	Odd Parity
		3	Even Parity
Stop Bit	5	1	1 Stop bit
		2	2 Stop bit
Density	6	1	Density Low
		2	Density Medium
		3	Density High
Quality	7	1	Low
		2	High

(Continue...)

	<b>POWER Lamp (Green)</b>	<b>ERROR Lamp (Red)</b>	<b>Option</b>
<b>Mark</b>	8	1	No use
		2	Use
<b>Sensor</b>	9	1	Low
		2	Medium1
		3	Medium2
		4	High
<b>Power Down</b>	10	1	No use
		2	1 minute
		3	2 minute
		4	3 minute
		5	4 minute
		6	5 minute

&lt; Table 4 &gt;

### 3. Interface.

#### 3.1. UART(RS-232C or TTL)

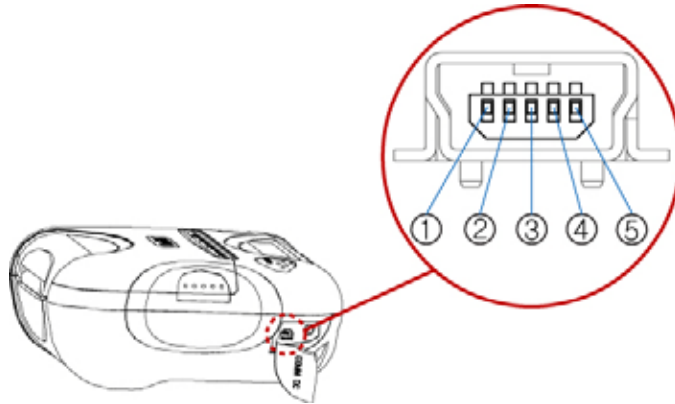

Pin No.	Name	Direction	Function
1	TxD	Output	Transmit Data
2	RxD	Input	Receive Data
3	CTS	-	-
4	NC.	-	-
5	GND	-	Ground

The WSP-i350 printer has a UART(RS-232C or TTL) interface and is connected by means of a 5 pin mini USB socket. In the following table, the signals present on the Mini- USB socket are listed:

**NOTE :** ● When data receiving, when it removes the communication cable, it loses a data.

### 3.2. Infrared data communication

The WSP-i350 has a serial interface for bi-directional data exchange.

The infrared port is the right side of the front part.

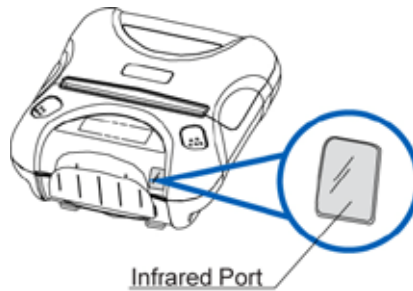

1. To use the WSP-i350's infrared port by a Computer or a Personal Digital Assistant (PDA) with IR port is required.
2. Position a PDA conforming to the specifications in point not more than 50 centimeter away from the printer's infrared port. Make sure the two ports are in front of each other with an angle of not more than 15° on the four sides.

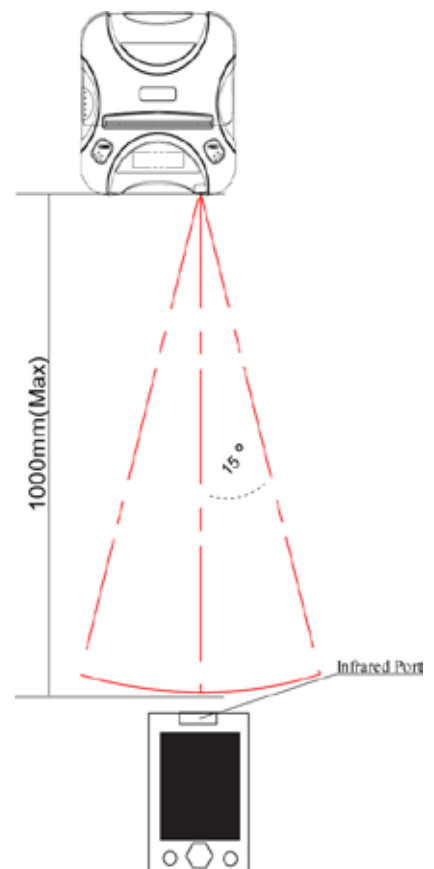

**NOTE :** ● When infrared ray communication doing, directness it does not see the IrDA window roll up.  
Eye damage there is a danger.

### 3.3. Bluetooth

Category	Specification
Bluetooth Spec.	Bluetooth Ver2.1 + EDR / Class2 (10m)
Frequency Range	2.4GHz ISM BAND
Data Transmission Rate	57600bps Fixed.
Data bit	8 Data bit Fixed.
Parity bit	No parity Fixed.
Stop bit	1 Stop bit Fixed.

### 3.4. Wireless LAN

Category	Specification	
Interface	Network	IEEE802.11b/g
Protocol	TCP, UDP, IP, ICMP, ARP, DHCP, PPPoE DNS lookup, DDNS(Dynamic DNS), WEP	
Communication Mode	T2S	TCP Server Mode
	COD	TCP Client Mode
	ATC	TCP Server / Client (AT command emulation)
	U2S	UDP

## 4. Using the printer.

### 4.1. Control panel.

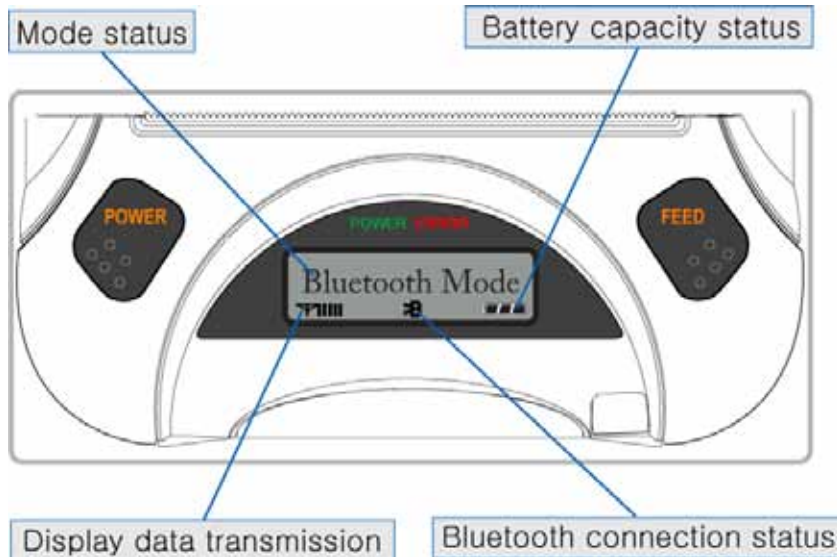

#### □ Button

##### - FEED Button :

When the printer is on, paper can be feed manually by pressing and holding the FEED button for more than one second.

##### - POWER Button :

When of 5 or more seconds presses and power comes to on or off.

After pressing the POWER and the FEED button simultaneously, if the ERROR lamp 5 turn signals POWER button is converted with MODE functions.

MODE functions are for use to change communication mode.

(Refer to **2.5. Set operation mode** for details about mode conversion)

#### □ Panel lamp

-POWER (Green) : Printer is ON and ready to receive data.

-ERROR (Red) : Indicated a fault condition or a printer error.

(i.e : no paper, paper cover opened. etc.)

## 4.2. The self test.

The self test procedure will check most of the printer functions.

For self test, turn on the power while holding down the FEED Button.

The Self-Test checks the following :

- 1) Make sure paper roll has been installed properly.
- 2) The Self-Test prints the current printer status, which provides the control ROM version and the communication method setting.
- 3) After printing the current printer status, Self-Test will print a pattern using the built-in character set.
- 4) The Self-Test automatically ends.

The printer is ready to receive data as soon as it completed the self test.

## 5. Consumable Parts.

### 5.1. Recommended paper.

Type	: Thermal Paper
Paper width	: 80mm
Paper thickness	: $60\pm 5\mu\text{m}$
Outer diameter	: $\varnothing 50\text{mm}$ or less
Recording side	: Outside of roll



#### Cautions

1. Do not paste the paper to the core. And the roll paper which has Near end mark printing on its near end is recommended.
2. Chemicals or oil may change the color of paper, or printed Characters may fade.
3. Change of paper color starts from approx 70 .  
Pay attention to heat, humidity and sun light.
4. Color of paper may be changed by being scratched by nail or hard metal, etc

### 5.2. Printing position.

